

▽ ROUGH MACHINED	(01) ROUGH CLEANING	ALTERATION
▽▽ FINISH MACHINED		① 08/2004
▽▽▽ FINE FINISH MACHINED		FIXING HOLES DELETED. DRG. ALTD. ACCRDLY. NOTE-1 REVISED. QTY. FOR SCN <sub>6</sub> ADDED WITH ASSY. DRG. No. SCN <sub>6</sub> -6-1-601.
		sd/-                      sd/- SSE/D                    SME/DSD
		② 05/2005
		NOTE-3 DELETED.
		SSE/D                    SME/DSD

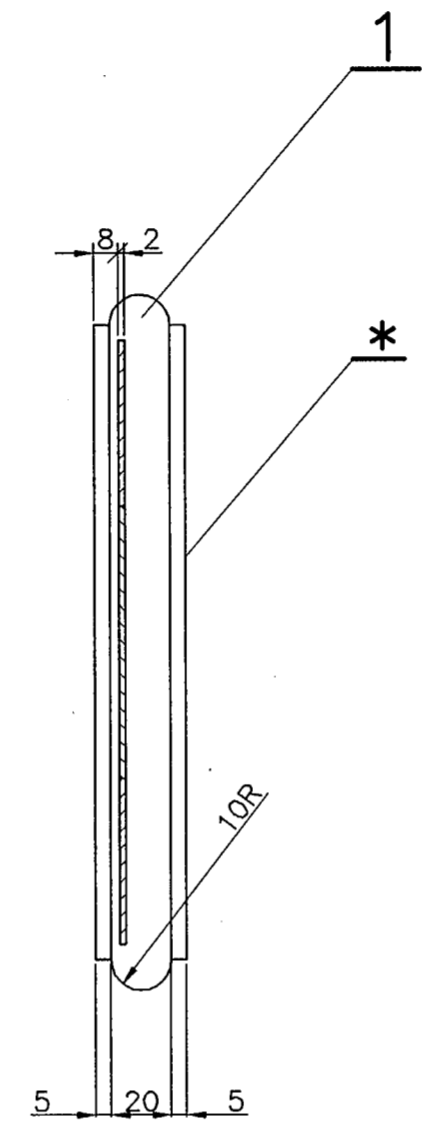
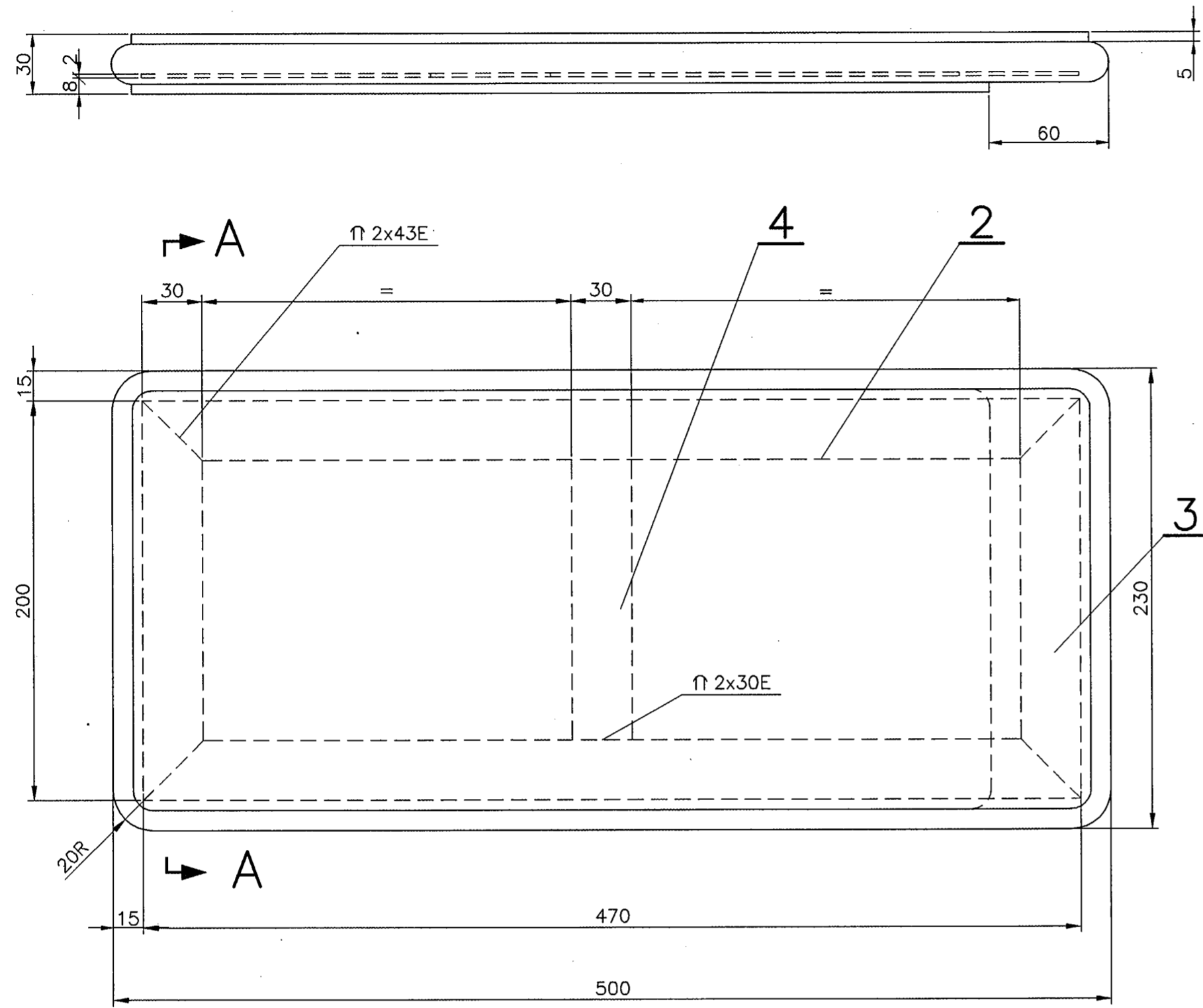

SECTION-AA

**NOTE:**

- \* 1. A STICKER TYPE NAME PLATE INDICATING THE MANUFACTURER'S NAME & YEAR OF MANUFACTURE PUNCHED OUT FROM WATER PROOF POLYCARBONATE OF 175 MICRON THICKNESS LAMINATED WITH PRESSURE SENSITIVE 3M 467 ADHESIVE OR SIMILAR IS TO BE PASTED AT THE LOCATION SHOWN HERE.
- 2. OPEN TOLERANCE TO DRAWING NO: ICF/STD-9-0-001 SHALL GENERALLY BE FOLLOWED.
- 3. SHORE HARDNESS 40<sup>+5</sup> CAN BE USED AND COLOUR TO FEATHER TOUCH BLUE 315 OF BHOR OR SIMILAR OR UNIVERSAL.
- 4. 8mm COMPREG SUPPORT IS ACCEPTABLE IN LIEU OF STEEL FRAME WORK.

NO. OFF ASSYS. REQD. PER COACH		
TYPE OF COACH	COL-1	
SCN <sub>5</sub>	27	
WGSCWAC <sub>4</sub>	23	
WGFCWAC <sub>7</sub>	10	
SLR <sub>2</sub>	2	
SCN <sub>6</sub>	27	

NO. OFF	DESCRIPTION & DIMENSIONS	ITEM	REF. DRGS.	MAT. & SPEC.	WEIGHT/UNIT	REMARKS
1	FLAT 2x 30x140	4		IS:1079-94 Gr 'O' SK		
2	FLAT 2x 30x200	3		IS:1079-94 Gr 'O' SK		
2	FLAT 2x 30x470	2		IS:1079-94 Gr 'O' SK		
1	PU FOAM (BLUE)	1		ICF/M/D/SPEC-102		
GROUP :- 6-1 SEATS & BERTHS					SUPERSEDED BY:	
					SUPERSEDES: SCN <sub>5</sub> -6-1-521 ALT j/-	
<b>HEAD REST FOR UPPER BERTH</b>					SCALE	SSE/D
					1:2.5	CHD
						TRD
						CAD
CAD FILE: C:\MD-CAD\171\6-1\521-SK00.DWG					ALT	j   k
DATA CODE NO: 171					INTEGRAL COACH FACTORY CHENNAI - 38.	
INDIAN RAILWAY STANDARDS					SHEET 1 OF 1	
					<b>SCN<sub>5</sub>-6-1-521</b>	

SCN <sub>6</sub> -6-1-601	
SLR <sub>2</sub> -6-1-201	
WGSCWAC <sub>4</sub> -6-1-425	
SCN <sub>5</sub> -6-1-501	
ASSEMBLY DRAWINGS	
14-05-2005	05-02-2003
ALT.	DATE OF LATEST ALTN.
	DATE OF FIRST ISSUE
	DY.CME/D
	SME/DSD