

DIRECT INVITATION OF TENDERS

SMM-D(ELS) ITARSI WEST CENTRAL RAILWAY invites Tenders to the supply of the following items are due for opening in this Office on 24-04-2014 at 14:00 PM .

The attention of Tenderers drawn to the fact that they should clearly indicate in their Quotations, the Origin, Maker's name Brand etc. of the material offered by them without which their quotations are liable to be rejected. They should only quote for the "UNIT" mentioned in the Tender List , otherwise their Quotations will not be considered.

Separate Quotations should be submitted for each item, otherwise their Quotations will not be considered.

The Tenders should be dropped in the Tender Box placed for this purpose in this office (SMM-D(ELS) WEST CENTRAL RAILWAY) only and not in the office of the Controller of Stores, Bombay , C.S.T. which please

- 1). As List attached , Drawing & Sample can be seen in the office.
- 2). Firm to submit a copy of valid ITCC alongwith the quotations and put Rubber stamp of their sales tax registration no. on Quotation with Gaurantee that Brand/Make of material will be supplied in original package.
- 3). 100% payment in advance will not be considered.
- 4). Payment after delivery against Receipt Note.
- 5). Inspection by Consignee / SMM-D(ELS) ITARSI

वरिष्ठा.प. (ई.एस.एस.) इटारसी
S.M.M.(ELS) ITARSI
SMM-D(ELS) ITARSI

Sr No	Tender No	PL No	Description	Quantity	Unit
1	70135252	00	Set of Arching stud tips only of HS-15250 TM Rocker ring and brush holder, As per Drg. No.SKEL 4707 Alt-1, One set consisting of 02 items 12 Nos. (06 Nos. Rocker ring side and 06 Nos. Brush holder side).	200.000	SET/03
2	70145030	23	Locking plate for Hitachi gear case fixing bolt, As per drg, no ELS/ET/TRS/BG/4/134 Ref.2.	1800.000	NOS./01
3	70145032	23	Silicon oil Product Name AVI Lubes-40 of M/s AVI Oil India (P) Ltd. Or Silicon Lubricant 1609 of M/s 3M/or Xlameter PMX-200 Silicon fluid 350 CST of M/s Dow corning or Silicon 20.300.000350 CST of M/s Matrix spaciality Lubricant in spray cane of 400ml capacity, Material to be procured from RDSO approved source or their authorised dealer only.	110.000	NOS./01 <i>Kandly action</i>
4	70145034	25	External male coupler cover assembly complete As per Drg. No. CLW/ES/C-8 Alt-H	150.000	NOS./01 <i>Kandly action</i>
5	70145035	23	Set of rubber gasket for Air strainer material Neoprine rubber Grade'C' IR-SR-48/88, One Set consisting of 02 items 02 Nos. 1) Rubber gasket for Sintered branze filter element capsul, Size ID-24mm, OD-30mm,, Thickness-2mm. 2) Rubber gasket for Air strainer, Size ID-40mm,OD-45mm, Thickness-3.15mm.	8000.000	SET/03
6	70145038	23	Electrical copper flat strip as per Drg. No ET/TRS/ELS/TR/4/044 or latest	5000.000	NOS./01
7	70145042	25	Set of Teflon gasket for copper pipe line MPH to conservator pipe line consisting of below mentioned items 1) Teflon gasket OD= 19mm, ID=5.5mm, Thickness = 3 mm Qty= 01 No/Set 2) Teflon gasket OD=24mm, ID=10mm, Thickness=3mm Qty=01 No/Set, One set consisting 02 items 02 Nos.	500.000	SET/03
8	70145043	23	Set of spares for horizontal yokes for induction heater Make Inventum type HIB-01 for heating of Auxilary motor bearing 6313, 6310, 6306, 6305, 6304 (For WAG-5, WAM-4 WAP-4 locos) One set consisting of 05 items 07 Nos. As per annexure attached. Make Inventum or Similar.	1.000	SET/03
9	70145044	23	Spring for lubricating pad & support assly for TAO-659 TM to Drg.No ELW/BSL/WAM4/4/110.314 Alt-1.	2500.000	NOS./01
10	70145045	00	Versalite powdered cleaner degreaser all metal safe powdered cleaner effective in removing of baked and charred oil grease shop soil and carbon, Packing size 01 Kgs.	20.000	KGS./13

Sr No	Tender No	PL No	Description	Quantity	Unit
11	70145046	00	"Pre laminated self adhesive sticker Size 11" x9" for instruction of Air Drier & Mobile operation of Electric locomotives Sticker back ground in Yellow colour & letter printed in Hind & English in black colour." As per Annexure.	500.000	NOS./01
12	70145047	25	Gasket for EMU Type After cooler base (Bottom) Drg.No.BSL/TRS/WAM4/SK-4/395 Make-Champion, TAL Bross & sheet with wire mesh.	120.000	NOS./01
13	70145048	25	Self locking nylon cable tie Size 104mmX 2.5mmX 1.00mm, Category kp 138 of M/s. Surelock Plastic Pvt. Ltd or similar.	30000.000	NOS./01
14	70145049	25	Hexagonal head screw Size m6x20, Property class 8.8, Make-LPS,Unbrako, GKW,TVS, .IS-1364. or equal.	2000.000	NOS./01

→ lend a tin to
 Champion
 &
 Tal bross

he
 SMM-D(ELS) ITARSI
 S.M.M.(ELS) ITARSI

70 14 5043

ANNEXURE

Set of spares for horizontal yokes for Induction heater Make Inventum type HIB-01 for heating Auxiliary motor bearing, One set consisting of 05 items 07 Nos. Vide, Requisition No. 57310032 date 06.03.14

SN.	Horizontal yokes size	Qty/Set
1	10x10x280mm	01 No.
2	14x14x280mm	02 Nos.
3	20x20x280mm	02 Nos.
4	30x30x280mm	01 No.
5	45x45x280mm	01 No.

Punit Jyoti
ADEE/TRS/ET.
सहा.सं.वि.इंजीनियर
(क.स.स्टा.) प.म.रेल, इटारसी
ADEE (TRS) W.C.Ry. Harid

S. S. S.
SSE/E-3A

① TAD 659

Regn No. SF31 0020

17/2/14

70145030

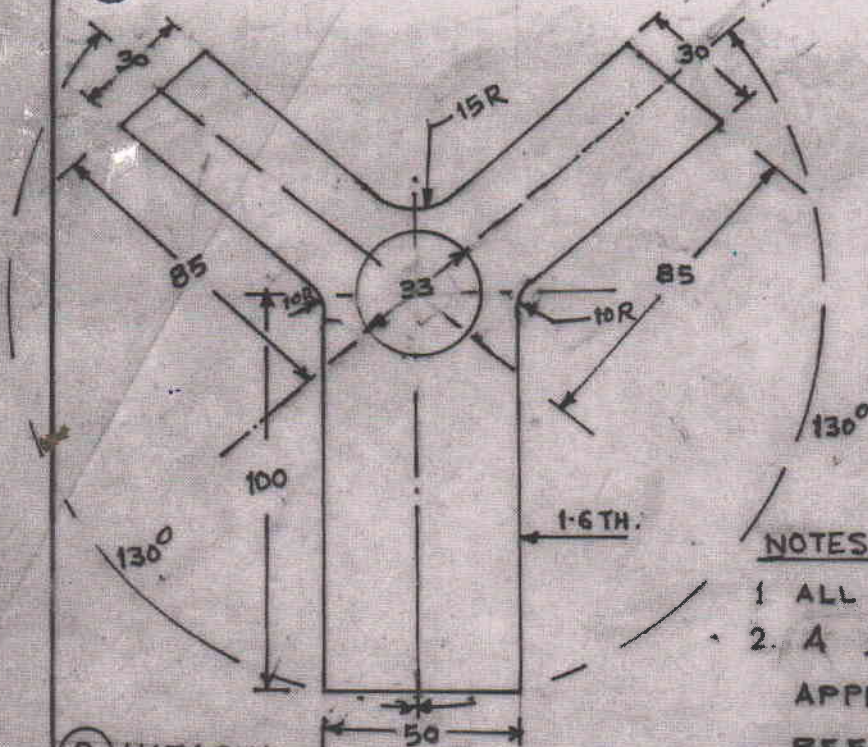

NOTES:

1. ALL DIMENSIONS ARE IN MM.
2. A SAMPLE SHOULD BE GOT APPROVED BY THE CONSIGNEE BEFORE SUPPLYING IN BULK QUANTITY.
3. GENERAL TOLERANCE AS PER IS. 2102 (MEDIUM)

② HITACHI

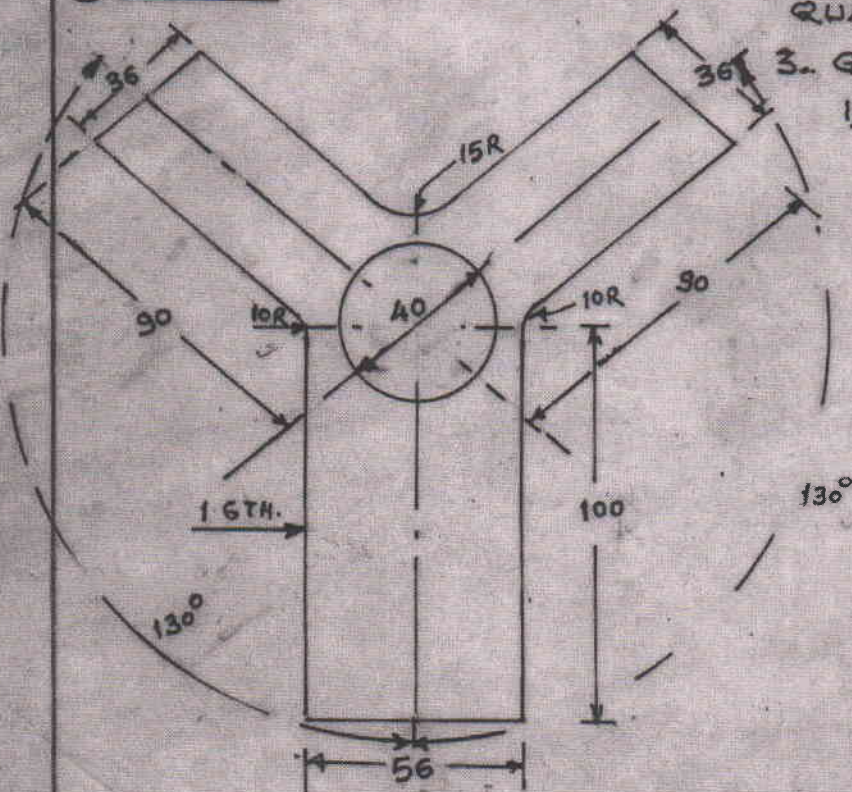

MASTER
TRACING

MATERIAL M.S. IS. 1079	SIGN. DT. DGN. <i>Dr. and</i> DRN TRD CHD <i>hmmms + gals</i> COMP. <i>filled 20. 3/12</i> SCALE: - NTS	SR. DEE (TRS) ^S . OFFICE ELS ET. LOCKING PLATE FOR GEAR CASE FIXING. BOLT. DRG. NO. ELS/ET/TRS/BG/04/134
---------------------------	---	---

A. V. S. Deo
f. SR. DEE/TRS/ET

70 14 5038

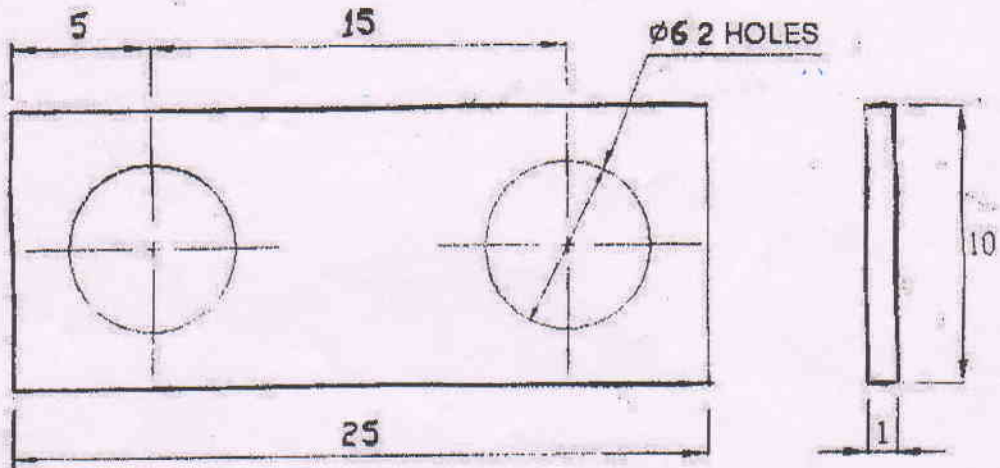

NOTE:-

1. ALL DIMENSIONS ARE IN MM.
2. ONE SAMPLE SHOULD BE SUPPLIED TO THE CONSIGNEE FOR APPROVAL BEFORE MANUFACTURING IN THE BULK QUANTITY.
3. MATERIAL:- ELECTRICAL COPPER.

		REF: AS PER SAMPLE.	WEST CENTRAL RAILWAY
		DESCRIPTION	
SSE/ E-6 (K.K.GUPTA)	<i>K.K.G.</i> 30/11/09	COPPER FLAT STRIP	<i>K.K.G.</i> 05/12/09 A.DEE/TRS/ET Sr. DEE/TRS/ELS/ET.
JE/ DRG	<i>3rd</i> 30/11/09		
DRAWN BY	<i>G. G.</i> 30/11/09		
SCALE	NTS	DRG.NO. ET/ TRS/ ELS/ TR/ 4/ 044	

- ❖ गाडी संचालन के दौरान मोबाईल का प्रयोग न करें।
- ❖ गाडी संचालन के दौरान अपना मोबाईल स्विच ऑफ/सायलेंट मोड में रखें।
- ❖ अपना मोबाईल बैग/बाक्स में रखें।
- ❖ केवल फेल्टोर/दुर्घटना या आपातकालीन परिस्थितियों के दौरान टी एल सी/कन्ट्रोल से आवश्यक सहायता मांगने के लिये ही मोबाईल का प्रयोग करें।
- ❖ Do not use mobile during run.
- ❖ During run keep your mobile in switch off/silent mode.
- ❖ Keep your mobile in bag/box.
- ❖ Use mobile only in case of failure/accident or any emergency requiring help from TLC/Control.



एयर ड्रायर हेतु निर्देश

INSTRUCTION FOR AIR DRYER

इस लोको में एचएडी स्विच लगा है, एयर ड्रायर सर्किट आईसोलेट करने हेतु इसे 0 पोजीशन पर रखें। एचएडी स्विच के 1 पोजीशन पर एयर ड्रायर कार्यरत रहेगा।

HAD switch is provided in this loco. To isolate air drier HAD switch to be kept on 0 position. Air drier will work at HAD in 1 position.

एयर ड्रायर को आइसोलेट करने के लिये कॉक 'ए' एवं 'बी' (हरे रंग) को बंद करें एवं कॉक 'सी' (लाल रंग) को खोले।

To isolate air drier cock 'A&B' (Green colour) to be closed and cock 'C' (Red colour) should be open.

वेल्डिंग एवं मेगरिंग करते समय एचएडी स्विच को 0 पर रखें।

HAD switch to be kept on 0 position during welding and meggering.

यदि सीसीए एवं सीसीबीए फ्यूज मेल्ट होता है तो एचएडी स्विच को 0 पर रखें।

HAD switch to be kept on 0 position if CCA and CCBA fuse melt.

बैट्री बाक्स नम्बर 1 में 35 एम्पीयर का फ्यूज लगा है।

35 Amp fuse is provided in battery box no. 1.

70143044

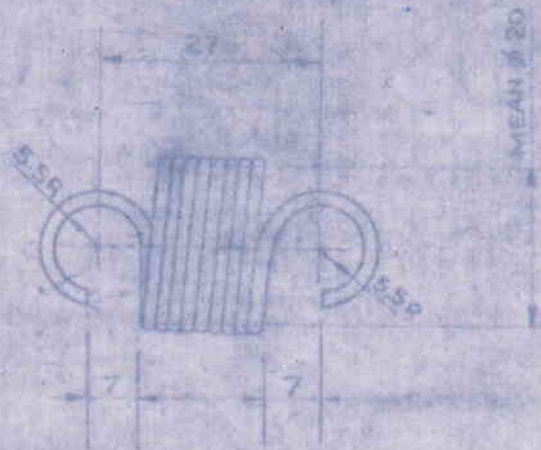

SPRING CHARACTERISTICS

- 1. WIRE DIAMETER ----- 1.8
- 2. NO. OF ACTIVE TURNS ----- 8
- 3. DEFLECTION UNDER A LOAD OF 5.2 Kg ----- 32 mm
- 4. MAX. ADMISSIBLE DEFLECTION WITHOUT ANY PERMANENT DEFORMATION ----- 53mm

NOTE:-

- 1. ALL DIMENSIONS ARE IN MM.
- 2. THE SUPPLIER SHALL SUPPLY THE SPRING IN NATURAL FINISH.
- 3. MATERIAL - HARDENED AND TEMPERED SPRING STEEL WIRE
- 4. TO IS: 4454 OR IS: 727 OR IS: 4454/67 OR IS: 727.
- 5. FINISHED SPRINGS SHOULD BE COATED WITH RUST PROOF VARNISH.
- 6. ONE SAMPLE SHALL BE GOT APPROVED FROM THE OFFICE OF THE JACOBS (AC) BHUSAVAL BEFORE BULK QUANTITY IS MANUFACTURED.

APPROVED BY: _____ DATE: _____ DESIGNED BY: _____ CHECKED BY: _____ DRAWING NO: _____	SWS/5420/301 25-94-8113	SPRING	SEE NOTE SPECIFIED
	P.E. NO. 41W0.092.154	DESCRIPTION REF. IN: 5001939	MATL. SPEC.
DATE: _____ SIGNATURE: _____	<h1>SPRING</h1>		SEE CHECKED
DR: _____ TR: 5-1-72 CH: _____ SCALE: 1:1	FOR LUG PAD & SUPPORT USE FOR TAIL TAG 650-A		CHECKED BY: _____ DATE: _____
DRAWING NO: _____			

70145047

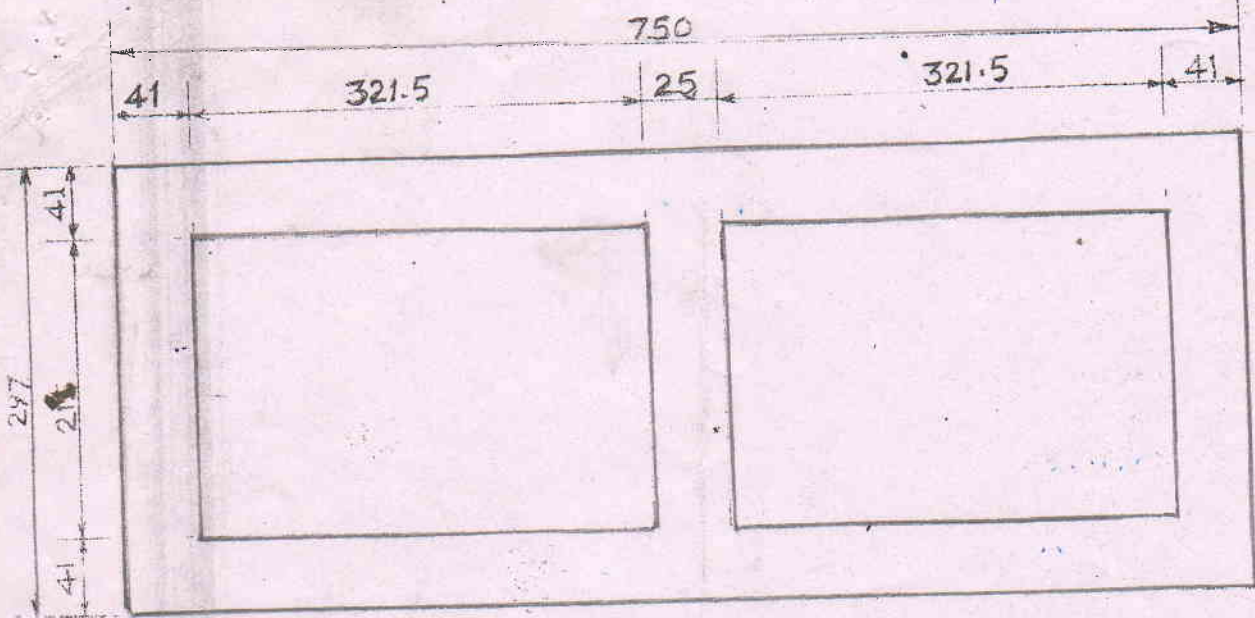

THICKNESS OF GASKET = 3.0 mm.

NOTE :-

1. ALL DIMENSIONS ARE IN MM.
2. ONE SAMPLE SHALL BE GO APPROVED FROM ST DEE/TRS/BSL THROUGH DCOB/ACL/BSL BEFORE BULK QUANTITY IS MANUFACTURED.
3. MATERIAL TO BE USED: COMPRESSED ASBESTOS FIBRE JOINTING SHEETS OF 10THICK GRADE W/2 TO IS: 2714-1974 WITHOUT WIRE MESH.

निदेश संख्या/	वर्ग	संख्या / वर्ग	वर्ग	विभाग
संख्या: 04.6.04	वर्ग: 04.6.04	संख्या: 04.6.04	वर्ग: 04.6.04	विभाग: 04.6.04
दिनांक	नाम	<p>GASKET FOR AFTER CGLER BASE (BOTTEM)</p>		
04.6.04	डॉ. के. काठिया			
04.6.04	डॉ. काठिया			
04.6.04	डॉ. काठिया			
04.6.04	डॉ. काठिया	<p>डॉ. काठिया डॉ. काठिया</p>		

DRG.No: BSL/TRS/WAM4/SK/4/395

CR