

ITEM NO.4

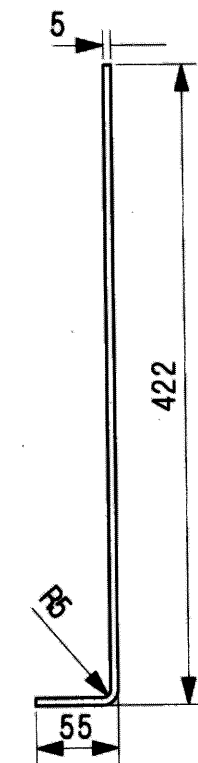
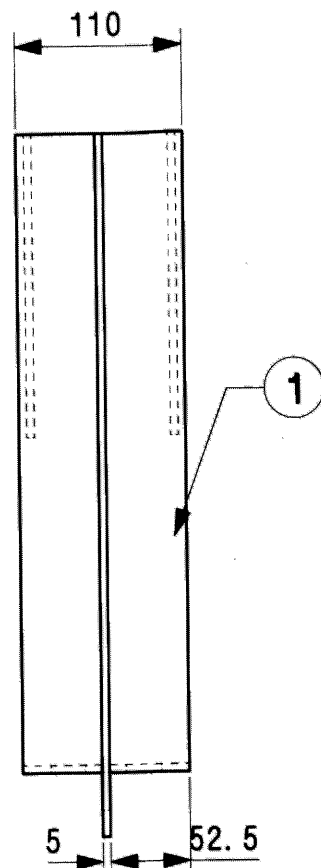
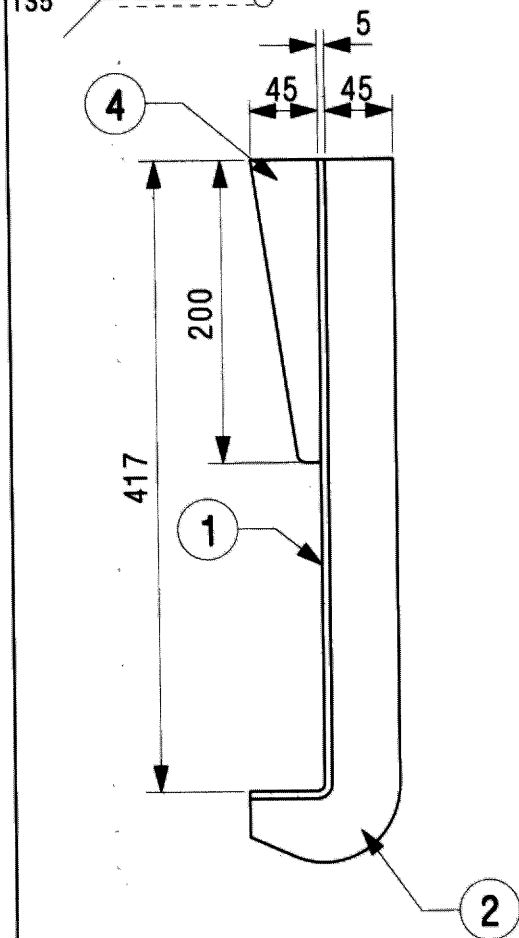

ITEM NO.1

ITEM NO.2

NOTE-

1. PROPER EDGE AND SURFACE PREPARATON MUST BE DONE BEFORE WELDING TO AVOID WELDING RELATED DEFECT.
2. SUITABLE JIGS AND FIXTURE SHOULD BE USED TO AVOID DISTORTION AND ALLIGNMENT RELATED PROBLEMS.

4	SIDE RIB SHORT 4X45X200	2			IRS-M41-97
3	SIDE RIB LONG 5X45X400	2			IRS-M41-97
2	J-RIB 5X100X464	1			IRS-M41-97
1	J-ANGLE 5X110X470	1			IRS-M41-97
ITEM	DESCRIPTION & DIMENSIONS	No. OFF	REF. DRG.	WT. OF ONE kg	MTL. & SPEC. REMARKS

SUPERSEDED BY:-		INDIAN RAILWAYS			
ASSEMBLY DRGS. SUPERSEDES:-		ICF/RCF TYPE COACHES			
REFERENCE :-	SCALE	P	MOUNTING BRACKET FOR IR-DRDE TOILETS		
	1:5	C			
		D			
		J.S.			
CDIC NO. :- K-503	B.G.	R.D.S.O. [CG]	CG-12041		

1	SS/17/13	ITEM NO. 3 DELETED AND NOTE ADDED.		
ALT.	ITEM	AUTH.	DESCRIPTION	CKD. DATE