

② 07/2009	▽ ROUGH MACHINED	① ROUGH CLEANING	ALTERATION
QTY. FOR ITEM-11 ALTD. FROM 60 TO 120.	▽▽ FINISH MACHINED		⑤ 05/2003 QTY. OF ITEMS-1&4 ALTD. FROM 8&7 TO 9&6 AND VIEWS ALTD. ACCORDLY. QTY. FOR WGSCZAC ₉ ADDED IN COL-I WITH ASSY. DRG. No. WGSCZAC ₉ -9-0-902.
Sd/- SSE/D	Sd/- SME/DSD		Sd/- SSE/D
			⑥ 12/2007 REMARKS FOR ITEM- 5&6 ALTD. FROM COL-III&IV TO COL-I&II RESPLY. NOTE-1 &MAT.SPEC. FOR ITEM-11 ADDED.
			Sd/- SSE/D
			③ 03/2008 LOCATION FOR ITEM-7 ADDED. MAT. SPEC. UPDATED
			Sd/- SSE/D
			④ 10/2009 LENGTH OF ITEM- 11 ALTD. FROM 25 TO 45.
			Sd/- SSE/D

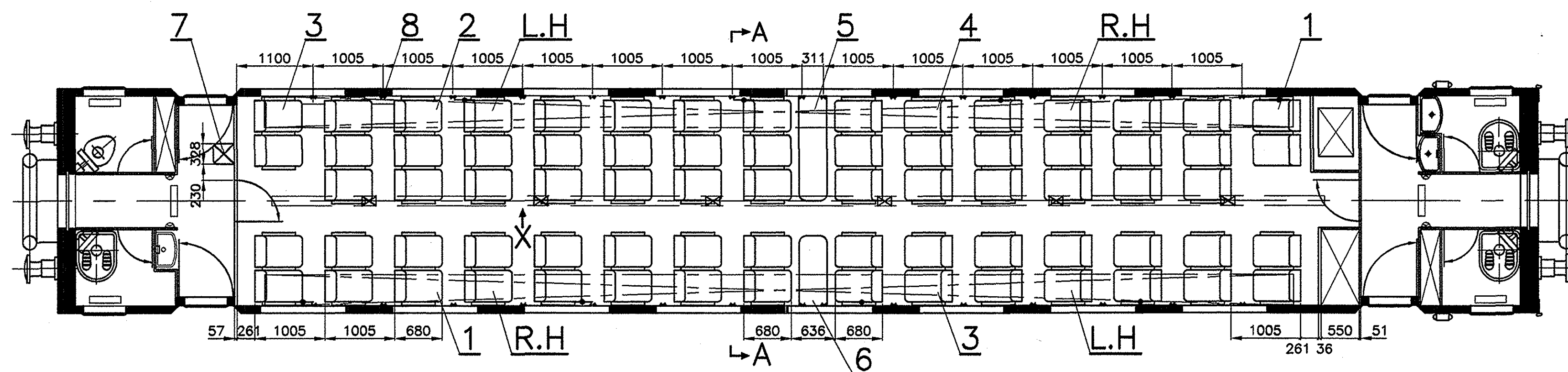

REFERENCE LAYOUT FOR WGSCZAC₈-9-0-801, WGSCZAC₉-9-0-901

NOTE:

1. GROOVES OF THE FIXING SCREWS SHALL BE FILLED WITH ARALDITE FOR ITEM-8.

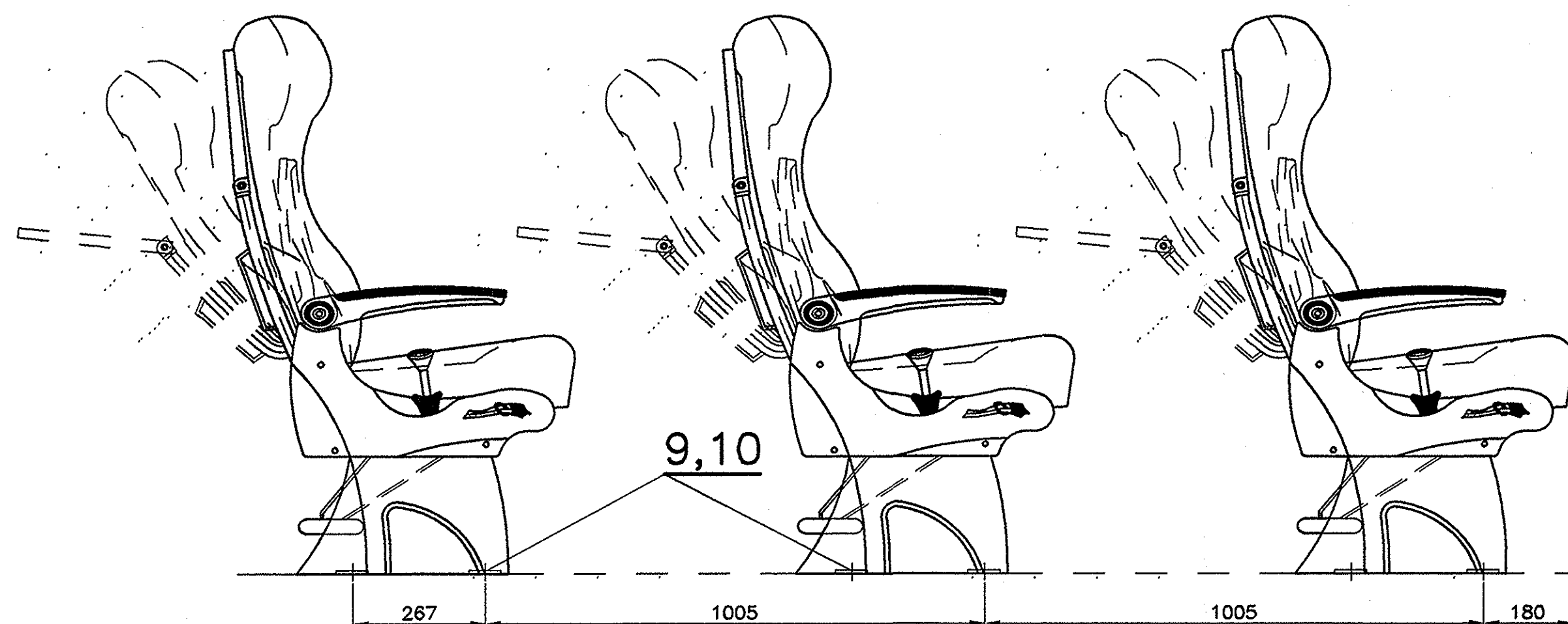

VIEW FROM-X

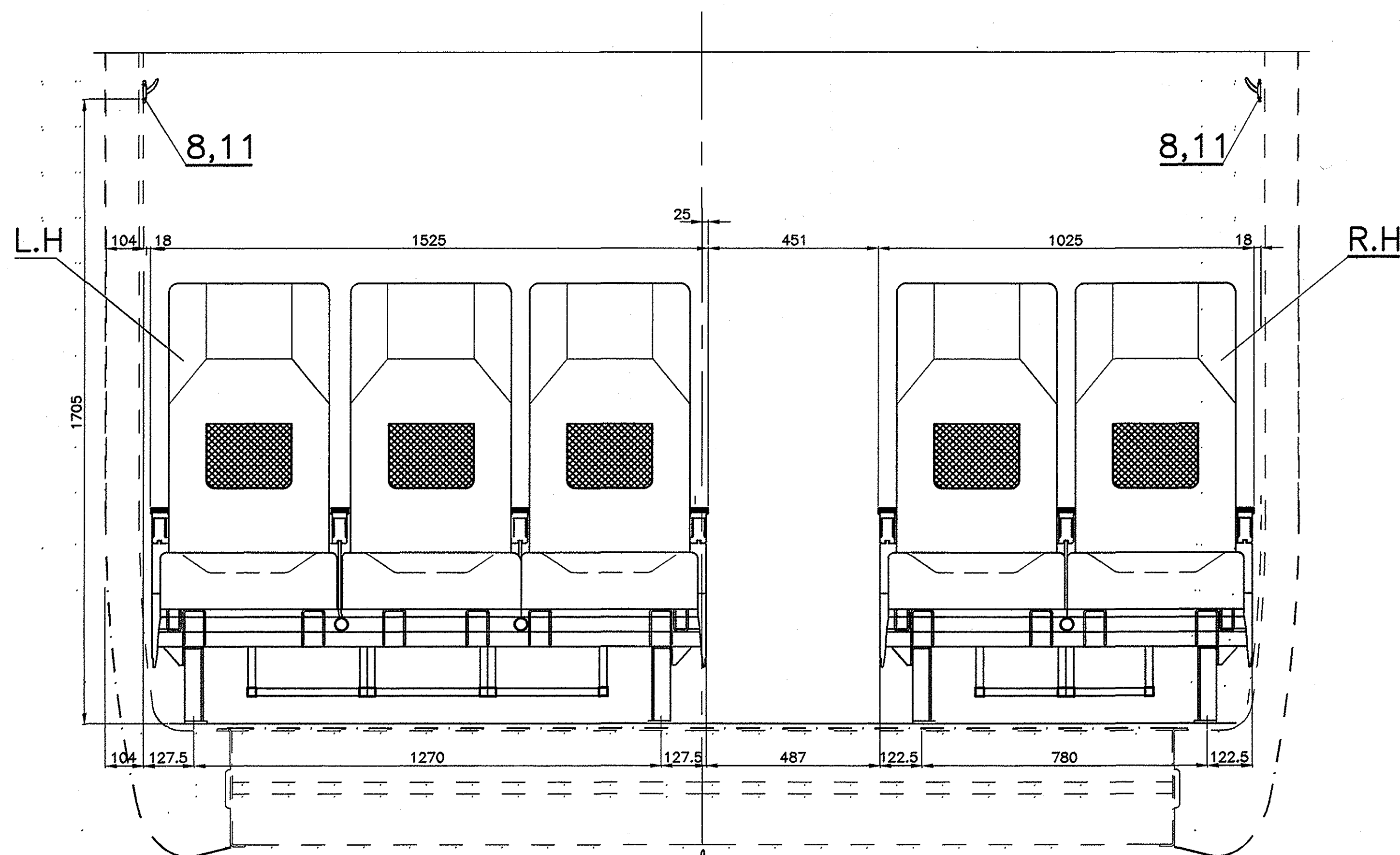

SECTION-AA

NO	OFF	DESCRIPTION & DIMENSION	ITEM	REF.DRG	MAT.& SPECN	WEIGHT/UNIT	REMARKS
11		RSD. C.S.K. HD. SCREW M5x45	11	IS:8911-78 4.8	IS:1367(P-14) 1984A2-70		
10		SPRING LOCK WASHER BB	10	IS:3063-94	IS:4072-75 GR-3		GALVD.
9		HEX. HD. SCREW M8x40	9	IS:1363(PART) 2002			GALVD.
8		COAT HOOK	8	ICF/STD 6-4-010			
7		ATTENDANT SEAT ARRGT.	7	ICF/SK 6-1-172			COL-I
6		SNACK TABLE	6	ICF/SK 6-4-325			COL-II
5		SNACK TABLE	5	ICF/SK 6-4-325			COL-I
4		3-SEATER WITH SNACK TABLE(R.H)	4	ICF/SK 6-1-394			ITEM-4
3		2-SEATER WITH SNACK TABLE (L.H)	3	ICF/SK 6-1-394			ITEM-3
2		3-SEATER WITH SNACK TABLE(L.H)	2	ICF/SK 6-1-394			ITEM-2
1		2-SEATER WITH SNACK TABLE (R.H)	1	ICF/SK 6-1-394			ITEM-1

WGSCZAC₉
WGSCZAC₈

WGSCZAC ₉ -9-0-902	22-10-09	12-04-2003	S.M.E./A.M.E.
WGSCZAC ₈ -9-0-802			
ASSEMBLY DRAWINGS			

NO OFF	DESCRIPTION & DIMENSION	ITEM	REF.DRG	MAT.& SPECN	WEIGHT/UNIT	REMARKS
GROUP :- 6-1 SEATS AND BERTHS						
SUPERSEDED BY						
SUPERSEDES: WGSCZAC ₈ -6-1-801 ALT c/2						
SCALE	SSE/D	CHD	ALT	DRN		
1:10						
1:50						
ALT.	b	c	d			
CAD FILE: C:\MD-CAD\244\6-1\801-SD02.DWG				INTEGRAL COACH FACTORY CHENNAI-38		
DATA CODE NO:	INDIAN RAILWAY STANDARDS			SHEET 1 OF 1		
244				WGSCZAC 8-6-1-801		