

▽ ROUGH MACHINED	(01) ROUGH CLEANING	ALTERATION
▽▽ FINISH MACHINED		① 08/2004
▽▽▽ FINE FINISH MACHINED		FIXING HOLES DELETED. DRG. ALTD. ACCRDLY. NOTE-1 REVISED. QTY. FOR SCN ₆ ADDED WITH ASSY. DRG. No. SCN ₆ -6-1-601.
		sd/- sd/- SSE/D SME/DSD
		Ⓚ 05/2005
		NOTE-3 DELETED.
		sd/- sd/- SSE/D SME/DSD
		① 04/2006
		NOTE-5 ADDED.
		<i>S. Siva</i> <i>S. Siva</i> SSE/D SME/DSD

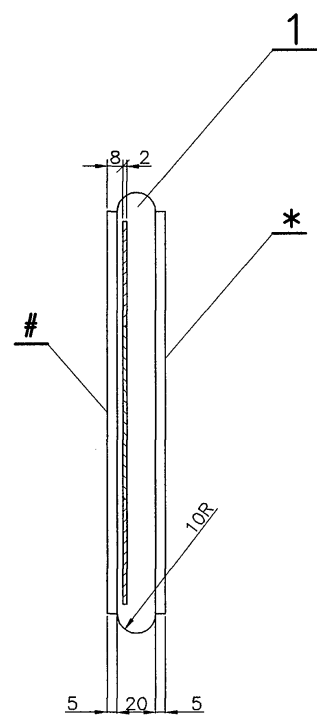
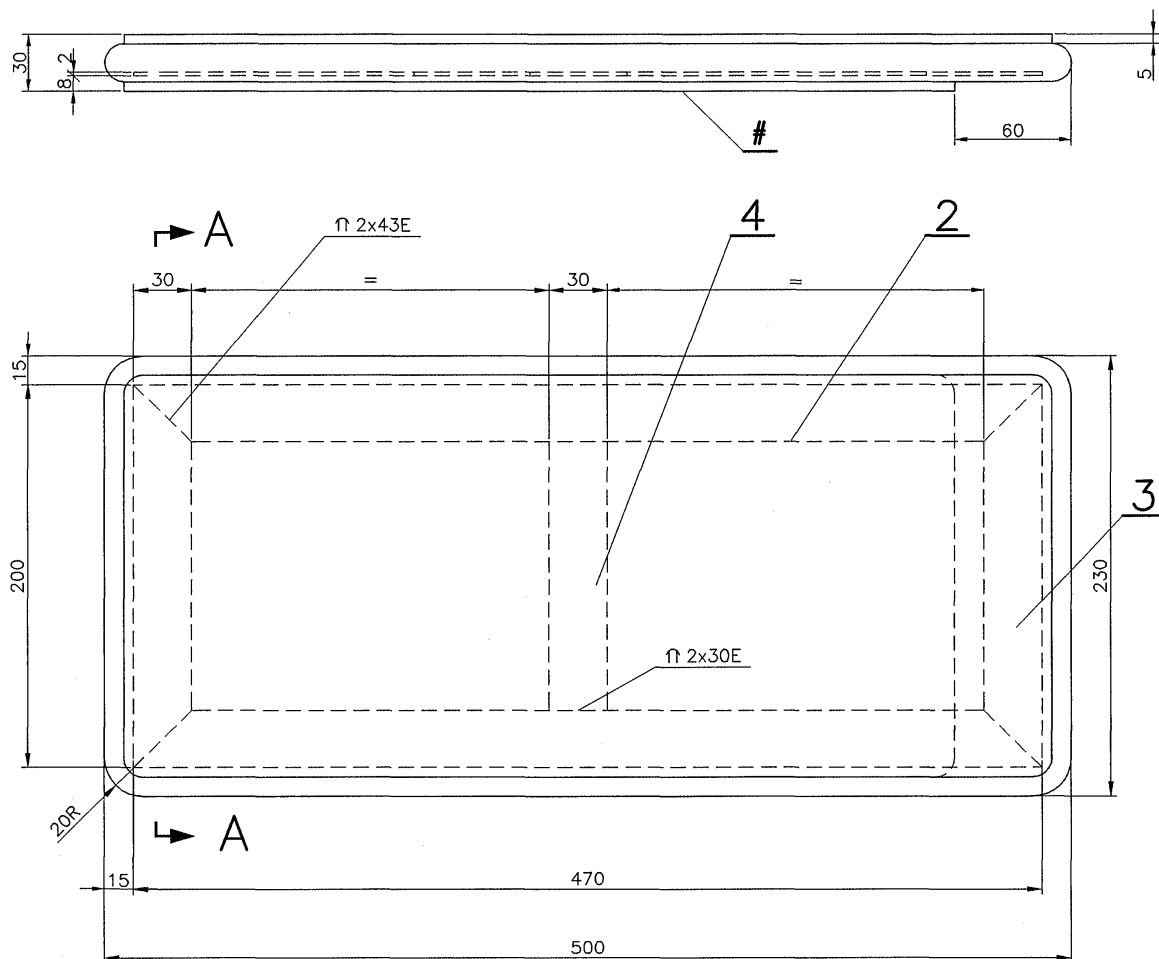

SECTION-AA

NOTE:

- * 1. A STICKER TYPE NAME PLATE INDICATING THE MANUFACTURER'S NAME & YEAR OF MANUFACTURE PUNCHED OUT FROM WATER PROOF POLYCARBONATE OF 175 MICRON THICKNESS LAMINATED WITH PRESSURE SENSITIVE 3M 467 ADHESIVE OR SIMILAR IS TO BE PASTED AT THE LOCATION SHOWN HERE.
- 2. OPEN TOLERANCE TO DRAWING NO: ICF/STD-9-0-001 SHALL GENERALLY BE FOLLOWED.
- ③ 3. SHORE HARDNESS 40⁺⁵ CAN BE USED AND COLOUR ~~TO FEATHER TOUCH BLUE 315 OF BHR OR SIMILAR OR UNIVERSAL~~
- 4. 8mm COMPREG SUPPORT IS ACCEPTABLE IN LIEU OF STEEL FRAME WORK.
- # 5. REAR OF HEAD REST SHALL BE WITH NATURAL COLOUR AND NO PAINTING WILL BE PERMITTED.

NO. OFF ASSYS. REQD. PER COACH		
TYPE OF COACH	COL-I	
SCN ₅	27	
WGSCWAC ₄	23	
WGFSCWAC ₇	10	
SLR ₂	2	
SCN ₆	27	

NO. OFF	DESCRIPTION & DIMENSIONS	ITEM	REF. DRGS.	MAT.& SPEC.	WEIGHT/UNIT	REMARKS
1	FLAT 2x 30x140	4		IS:1079-94 Gr 'O' SK		
2	FLAT 2x 30x200	3		IS:1079-94 Gr 'O' SK		
2	FLAT 2x 30x470	2		IS:1079-94 Gr 'O' SK		
1	PU FOAM (BLUE)	1		ICF/M/D/SPEC-102		
GROUP :- 6-1 SEATS & BERTHS						
HEAD REST FOR UPPER BERTH					SUPERSEDED BY:	
					SUPERSEDES: SCN ₅ -6-1-521 ALT k/-	
CAD FILE: C:\MD-CAD\171\6-1\521-SL00.DWG DATA CODE NO: 171 INDIAN RAILWAY STANDARDS					SCALE	SSE/D
					1:2.5	CHD
						ALT
						CAD
SHEET 1 OF 1 INTEGRAL COACH FACTORY CHENNAI - 38.					SCN ₅ -6-1-521	
					FORM IR A2 420X600	

ASSEMBLY DRAWINGS	DATE OF LATEST ALTN.	DATE OF FIRST ISSUE	DY.CME/D	SME/DSD
SCN ₆ -6-1-601	03-04-2006	05-02-2003		
SLR ₂ -6-1-201				
WGSCWAC ₄ -6-1-425				
SCN ₅ -6-1-501				