

1	2	3	4	5	6	7	8	9	10	11	12	13
---	---	---	---	---	---	---	---	---	----	----	----	----

ALT. NO.	ALT. DATE	ZONE	ALTERATIONS	AUTHORITY
NIL	NIL	NIL	NIL	NIL

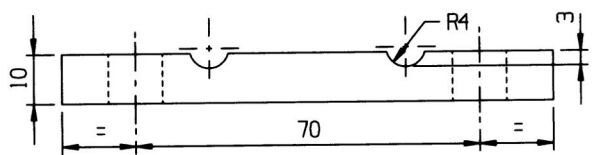
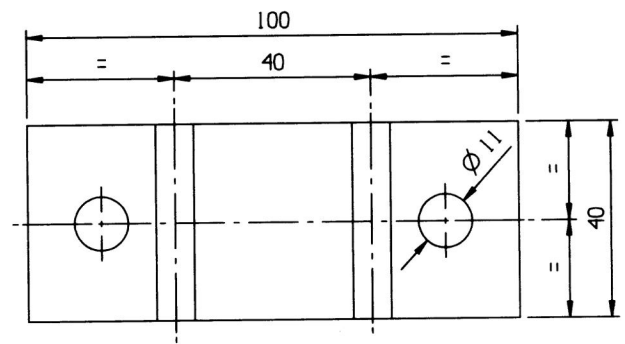

**NOTE :-**  
# 1. EQUIV. TO AISI: 304 S1

Checked  
#  
Date  
Inte  
प्रविष्टिया की  
Date Base

MAY

WELD LENGTH	WELD TYPE	DESCRIPTION & DIMENSIONS	SPASLT	DETAIL DRG	MATL. & SPEC.	REMARKS
NIL	M	LAVATORY & IT'S FITTINGS		DRWNO: NIL		
WEIGHT	FILE	/users2/furnish/lvtry/cc63115.prt				
0.300	KG	SCALE: DBE/REC				
S. AREA	M <sup>2</sup>	1:1				
NIL	M <sup>2</sup>	DRW				
LENGTH / S-A	M	RAIL COACH FACTORY, KAPURTHALA				
0.100	M	REF. NO. 40570				
WIDTH / THICK	INDIAN RAILWAYS STANDARD				PL NO. 00205400	
0.040/0.010	FROZEN				DRG. NO. CC63115	
HEIGHT	M	Material	Drawn	Rev	BY	DATE
NIL	M	304	Ravi	1.5.01		

DETAIL DRGS STARTING WITH "LI" ARE INTERNAL REFERENCE LISTS ONLY AND ARE NOT FOR ISSUE.  
THIS IS A COMPUTER GENERATED DRAWING. ANY MANUAL ALTERATION SHALL AUTOMATICALLY RENDER IT INVALID.  
FOR UNTOLERANCED DIMENSIONS REFER MDG0008

1	2	3	4	5	6	7	8	9	10	11	12	13
---	---	---	---	---	---	---	---	---	----	----	----	----