

- NOTE:**
1. OPEN TOLERANCE TO DRG. NO. ICF/STD-9-0-001 SHALL GENERALLY BE FOLLOWED WHENEVER TOLERANCE IS NOT MENTIONED FOR DIMENSIONS.
  2. WHILE WELDING THE FRAME CARE SHOULD BE TAKEN TO MAINTAIN THE SQUARENESS/FINISH OF THE STRUCTURE.
  3. ALL SWAMP CORNERS/EDGES TO BE ROUNDED OFF.
  4. THE WELDING SHALL BE ADAPTED.

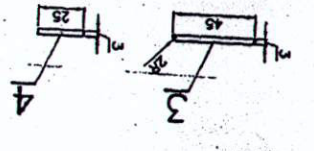
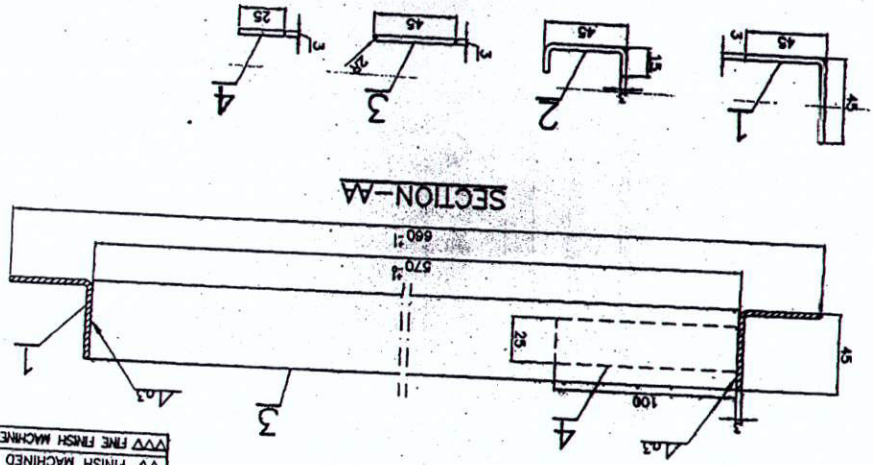
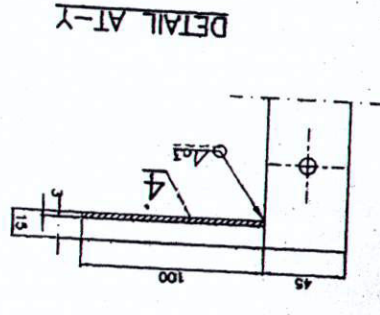
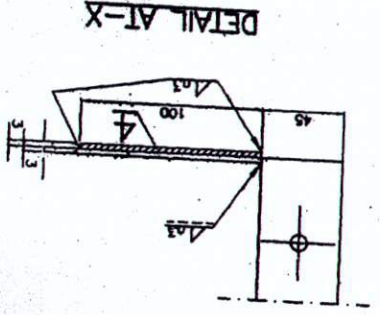

NO	OFF	DESCRIPTION & DIMENSIONS	ITEM	REF. ORG.	MAT. & SPEC.	WEIGHT/UNIT	REMARKS
2		BACK PIECE	4		4x25x100		
1		BOTTOM FLAT	3		L-570		
1		TOP CHANNEL	2		L-570	ASIS 304	
2		SIDE ANGLES	1		L-1888		

GROUP: 5-6

INDIAN RAILWAY

ICF/SK3-5-6-014

ASSEMBLY DRAWINGS

27/09/2014

DATE

NO. OF LINES AT DATE OF ISSUE

DATA

CD FILE: C:\MD-CAD\32815-6\328 5-6 016--00.dwg

PER ASST.

NO. OF SHEETS

SHEET

INTEGRAL COACH FACTORY

CHENNAI-35

ALT

1:2

1:2.5

1:5

1:1

SCALE SSE/D

SUPERSEDED BY:

REMARKS

WEIGHT/UNIT

MAT. & SPEC.

REF. ORG.

DESCRIPTION & DIMENSIONS

ITEM

NO. OF

NO. OF SHEETS

INDIAN RAILWAY

ICF/SK3-5-6-014

ASSEMBLY DRAWINGS

27/09/2014

DATE

NO. OF LINES AT DATE OF ISSUE

DATA

CD FILE: C:\MD-CAD\32815-6\328 5-6 016--00.dwg

PER ASST.

NO. OF SHEETS

SHEET

INTEGRAL COACH FACTORY

CHENNAI-35

ALT

1:2

1:2.5

1:5

1:1

SCALE SSE/D

SUPERSEDED BY:

REMARKS

WEIGHT/UNIT

MAT. & SPEC.

REF. ORG.

DESCRIPTION & DIMENSIONS

ITEM

NO. OF

NO. OF SHEETS

△	ROUGH MACHINED
①	ROUGH CLEANING
②	BURRS REMOVED
△△	FINE FINISH MACHINED
③	CHAMFERED

ALTERATIONS